

200M

Meteorological Humidity System

The Edgetech Instruments Model 200M is a complete instrument for the measurement of atmospheric dew/frost point, ambient temperature, percent relative humidity, or other psychrometric variables. It employs the very reliable chilled mirror sensing technique which provides a primary measurement of dew/frost point temperature. Its accuracy certification is traceable to NIST.

The Model 200M is ideally suited for installations requiring continuous, automatic, and unattended measurement of humidity over a very wide range. It is typically used in applications requiring precise environmental monitoring of atmospheric conditions.

Its Automatic Balance Control (ABC) cycle corrects the light reducing effects of mirror contaminants and allows for continuous monitoring and virtually maintenance-free operation. This is the first chilled mirror technology to truly reduce the need for mirror cleaning by the incorporation of self diagnostics, which indicate to the user, locally via an LED light source and remotely via a logic level TTL signal, when and if maintenance is required.

The Model 200M consists of a motor-aspirated, thermally shielded enclosure for the dew/frost point and ambient temperature sensors, an environmentally suited microprocessor based electronic control unit with psychrometric parameter computing circuitry and 25 feet of interconnecting cable. The 200M measures dew/frost point in degrees C or degrees F.

Dew/frost point temperature measurement is made using a direct measuring sensor utilizing a two stage Peltier cooled chromium plated mirror, automatically held at the dew/frost point temperature by a photo-sensing, condensate detecting, optical system incorporating an LED light source and photodetector. As condensate forms on the mirror, the optical sensing bridge detects the change in light level that occurs when dew or frost forms and develops a proportional control signal that modulates the thermoelectric cooler current. This control scheme permits the mirror to continuously track the dew/frost point. It is a primary method of determining the dew/frost point and hence the water vapor content of the gas. The mirror temperature represents the true dew/frost point temperature and is measured by an embedded, precision platinum resistance thermometer. Below 0°C, the system tracks the frost point.

All Edgetech Instruments dew/frost point hygrometers are manufactured and supported in the USA in a modern, ISO 9001:2015 registered facility with ISO/IEC 17025:2017 accredited calibration laboratory. The 200M is delivered with a NIST traceability certificate.



The Edgetech Instruments 200M

Features:

- Primary method measurement technique
- High accuracy and reliability
- Certificate of traceability to NIST provided
- Sensing scheme discriminates between dew/frost and contamination
- Reduced maintenance requirements
- No drift, no hysteresis
- Fast response
- No sensor calibration required
- Self-diagnostics and continuous unattended operation
- No balancing or other adjustments required

Applications:

- Nuclear power plants
- Power and process industries emissions monitoring
- External testing facilities
- Test tracks



 **Edgetech Instruments**

ISO/IEC 17025:2017 Accredited
ISO 9001:2015 Registered

Technical Specifications

Sensor Type:

Primary method, thermoelectrically cooled, chilled mirror dew/frost point temperature sensor

D2 with two stage cooling

Measurement Ranges:

Dew/Frost Point:

-40°C to 50°C (-40°F to 122°F)

at 25°C ambient

Dew/Frost Point Depression:

65°C (117°F)

Ambient Temperature:

-50 to 50°C (-58 to 122°F)

Temperature sensor (platinum resistance thermometer): 100 ohms at 0°C

Relative Humidity:

Approximately 1% to 95%

Accuracy:

Dew/frost point, $\pm 0.25^\circ\text{C}$ ($\pm 0.5^\circ\text{F}$)

Ambient temperature, $\pm 0.25^\circ\text{C}$ ($\pm 0.5^\circ\text{F}$)

Relative humidity, ± 1.0 to 1.5%

Outputs:

0-5 Vdc or 4-20 mA over dew/frost point span, TTL compatible clean mirror signal

Power:

90-260 Vac, 50-400 Hz, 40 watts maximum, RFI and line surge protection provided

Options:

Ambient temperature kit

Humidity computer (% RH or other psychometric variables)

Air flow switch to monitor presence or absence of flow through the aspirator

Signal output relay contact closure

Analog outputs, consult factory for list of available output options

Relay contact closure for clean mirror signal

Interconnecting cable (over 25 ft.)

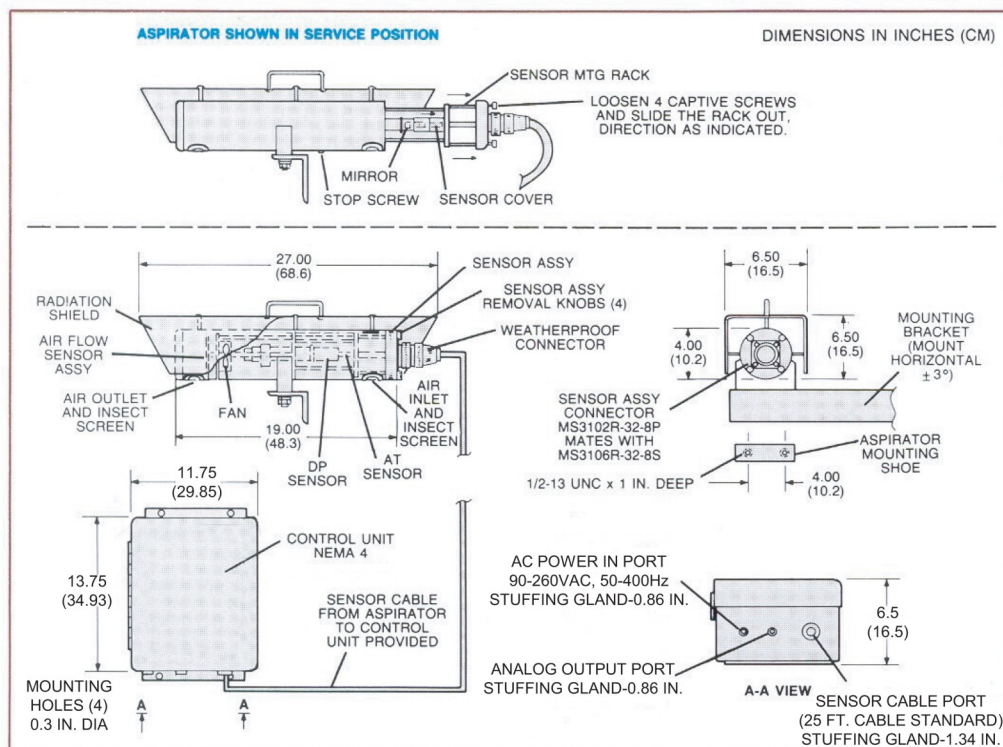

Made in USA

Toll Free: 800-276-3729 Ph: 978-310-7706 Fax: 978-310-7767

E-mail: H2O@edgetechinstruments.com

Web: www.edgetechinstruments.com

Rev. v8



Edgetech Instruments

ISO/IEC 17025:2017 Accredited
ISO 9001:2015 Registered