

CAM Operation w/ Model HPP125/ HP125 Probes		
CAM OPERATION NOTE	Reference Only	
	RJN	March 16-16
Edgetech Instruments Inc.	SK-O-HP-03162016A	

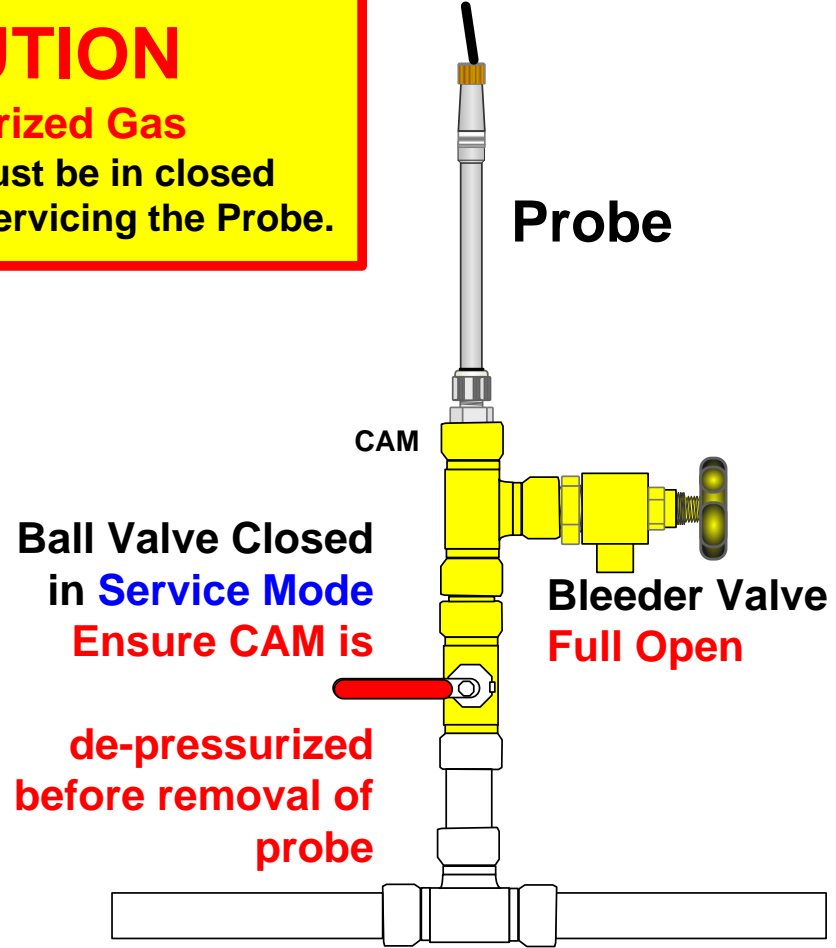

CAUTION
Pressurized Gas
Ball Valve must be in closed position when servicing the Probe.

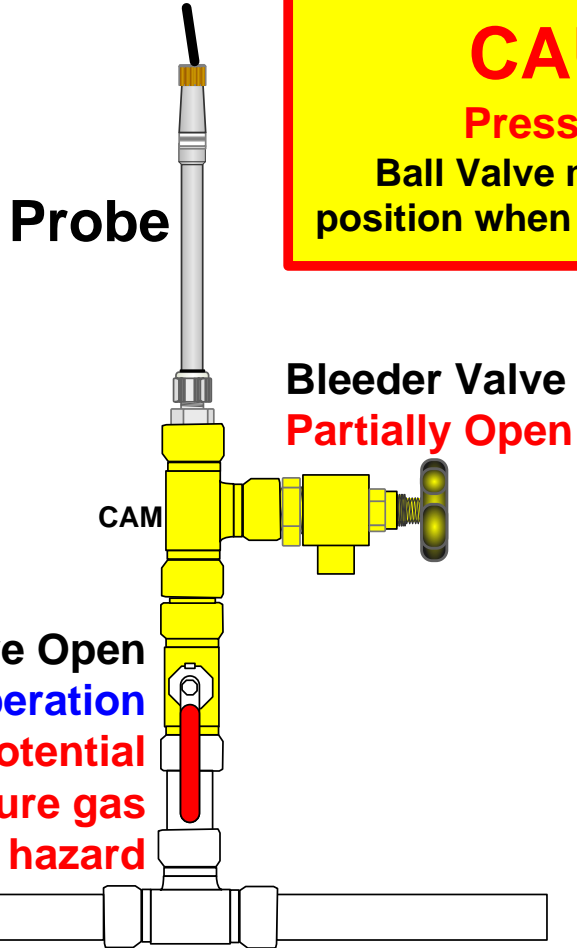

HAZARD WARNING CAM OPERATION		
CAM OPERATION	Reference Only	
	RJN	MARCH 16, 16
Edgetech Instruments Inc.	SK-WL-03162016A	

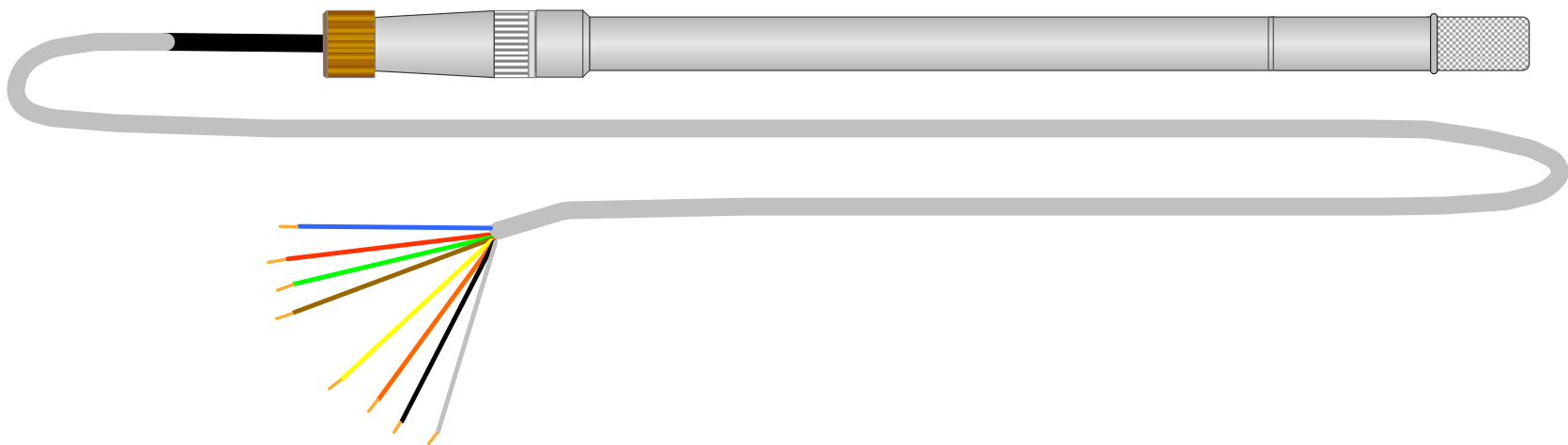
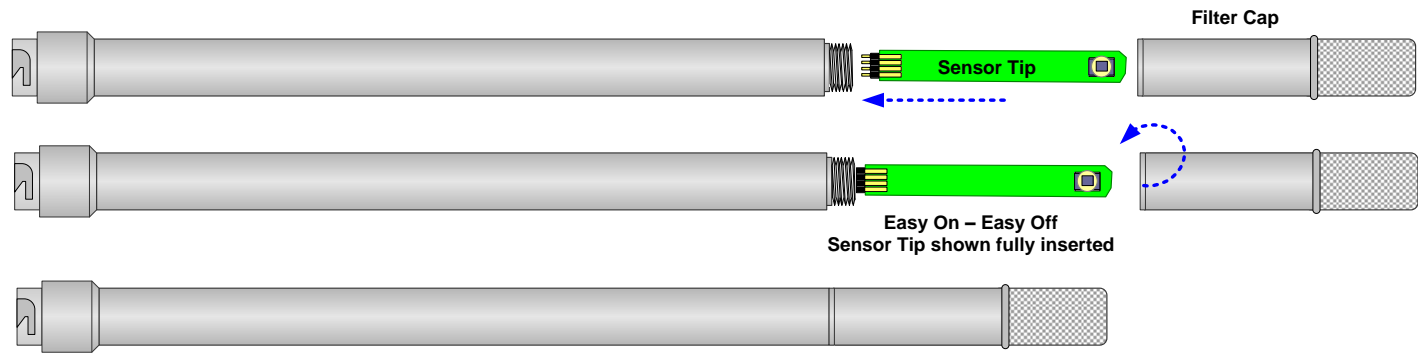

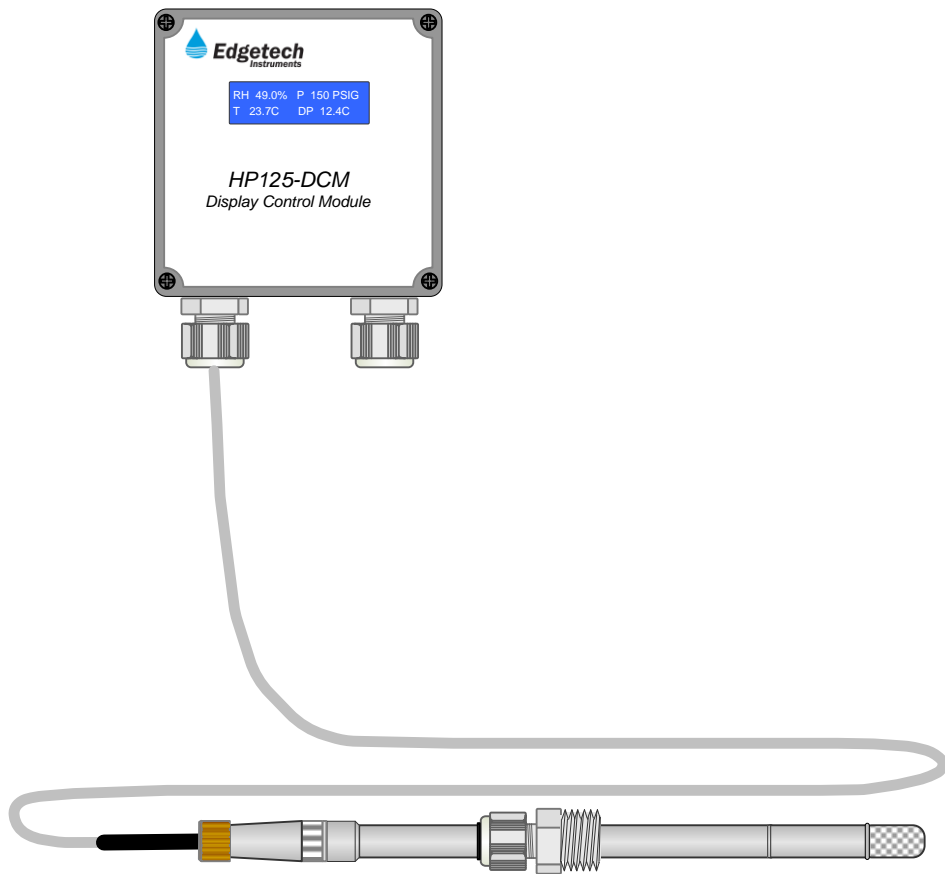

STANDARD MALE CONNECTOR MOUNT
1/2 in NPT or 3/4in NPT

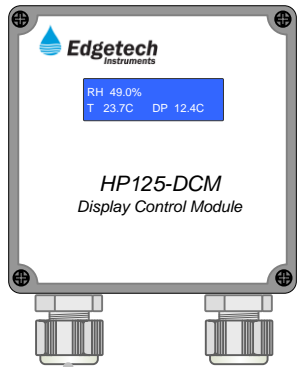

OUTPUTS
Analog Voltage & 4-20 mA
RS-232 Serial Interface
Alarm Relays
Standard 24 VDC Power

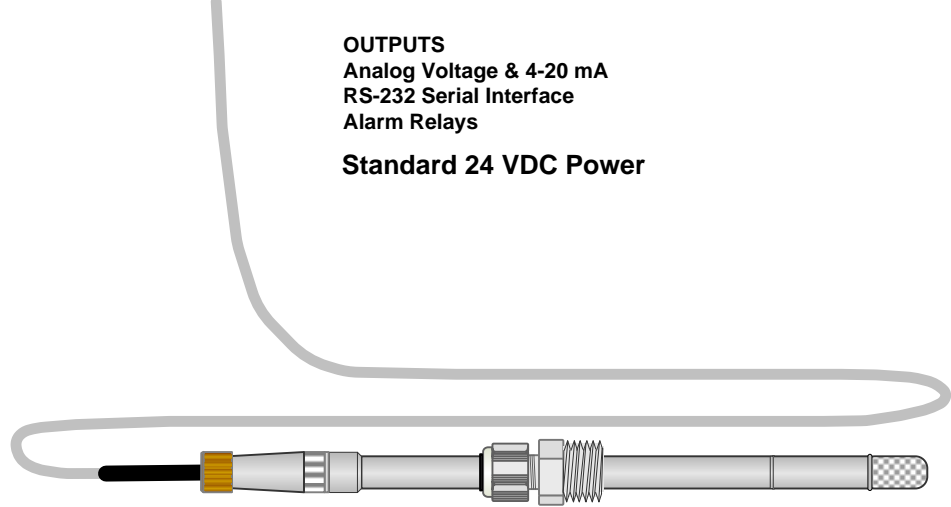

STANDARD MALE CONNECTOR MOUNT
 $\frac{1}{2}$ in NPT or $\frac{3}{4}$ in NPT

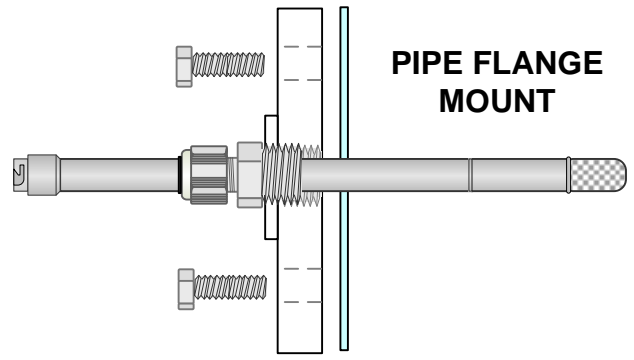

PIPE FLANGE MOUNT

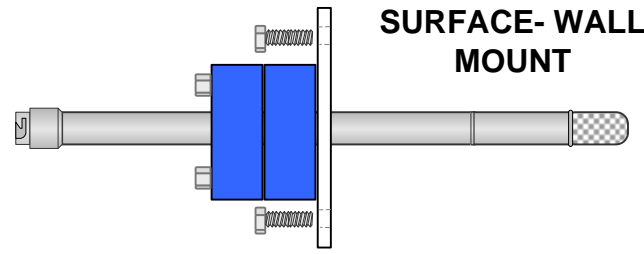

SURFACE-WALL MOUNT

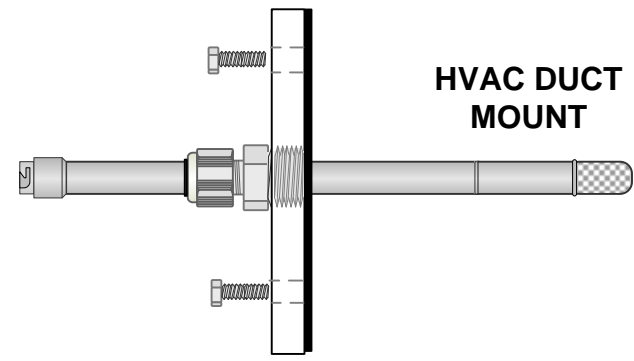

HVAC DUCT MOUNT

Probe Penetration Fitting

Adjustable Depth into process penetration point

Standard: 1/2" or 3/4" NPT

Metric Thread Sizes available

